

ConstructionSkills Learning Exercise

Practice Questions August 2007



Practice Answer Sheet

- | | |
|--|--|
| <p>1 A B C D
 () () () ()</p> <p>2 A B C D
 () () () ()</p> <p>3 14 15 16 17
 () () () ()</p> <p>4 1 2 3 4
 () () () ()</p> <p>5 A B C D
 () () () ()</p> <p>6 R323 R420
 () ()</p> <p> C20 W940
 () ()</p> <p>7 R323 C64(D)
 () ()</p> <p> C35 W911
 () ()</p> <p>8 C64(D) C20
 () ()</p> <p> C35 W940
 () ()</p> <p>9 A B C D
 () () () ()</p> <p>10 A B C D
 () () () ()</p> | <p>11 2 3 5 8
 () () () ()</p> <p>12 2 3 4 5
 () () () ()</p> <p>13 A B C D
 () () () ()</p> <p>14 Chemoblast Removate
 () ()</p> <p> PL-Chemicals Decote
 () ()</p> <p>15 2 3 4 5
 () () () ()</p> <p>16 30.1 37.1 44.75 301
 () () () ()</p> <p>17 A B C D
 () () () ()</p> <p>18 ZJ070 ZJ114
 () ()</p> <p> YD760 WA440
 () ()</p> <p>19 1500 2500 3000 3500
 () () () ()</p> <p>20 60 120 142.5 300
 () () () ()</p> |
|--|--|

Instructions

As a part of CITB's selection procedures for training places in the Construction Industry you will be asked to do a skill learning exercise. This booklet has been sent to you to help you prepare for that exercise and:

- shows you the sort of thing you have to learn in the exercise.
- gives some examples of the sorts of question you will be asked to answer.
- gives some hints on how to tackle the exercise.

In the exercise, you have to learn some of the sorts of skills you will need to work in the Construction Industry and then answer some questions to see how well you have learned them.

Everything you need to know is given in *Information Sheets*. They are always on a left-hand page. They tell you what you need to know to answer the questions. You can go back and read them again at any time. Sometimes you will need to use some common sense as well as following the instructions.

The questions in this practice exercise are all based around building plans for bungalows. These are not real plans and have been designed specially for this exercise. Some of the information reflects real practice in the Construction Industry but some of it doesn't. If you have worked with building plans before, some of what you see may be familiar, but **beware** – the exercise is not based on any particular system.

You have to answer two sorts of question. In the first sort you have to look at pictures which are views of the outside walls of the plans and say which view is closest to what the plans show. The view you have to look at is shown on the plans by a numbered arrow pointing at the relevant wall.

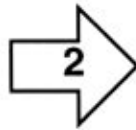

In other sorts of question you have to do some sums based on the information in the plans, or work out answers using graphs or tables.

Answering the questions

In the real exercise there is a separate answer sheet. In this practice exercise use the answer sheet on the inside of the cover on the page opposite. You give your answer by putting a mark in the appropriate box. Look at the example of part of an answer sheet below. Imagine that you had answered A to question 1 and 0.7 to question 2.

1	A	B	C	D	2	0.2	0.4	0.6	0.7
	—	—	—	—		—	—	—	—

The information and questions in this practice exercise are different from what you will see in the real exercise, but they are of the same sort and about the same level of difficulty. The real exercise will be timed so, before you start the examples, check the time and see how long this practice takes.

Answers to the examples are given on the inside of the back page but don't look at them until you have tried all the questions.

Now, turn over the page and read the first information sheet and then try the examples on the following pages.

Information Sheet 1

Below is shown a plan of a bungalow. Six different bits of information are shown on the plan: walls, windows, doors, guttering, drainpipes, and the length of some of these features.

Walls made of brick are shown like this on plans:



and are shown like this in the views of the buildings:

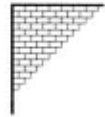

Plain glass windows are shown like this on plans:



and like this in the views:



Windows with hinges are shown like this on plans:

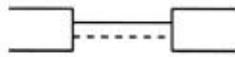

and like this in the views:

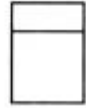

Solid doors are shown like this on plans:

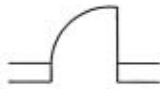

and like this in the views:



Guttering is shown like this on plans:

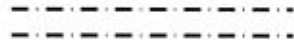

and like this in the views:



Drainpipes are shown like this on plans:



and like this in the views:



The length of features, is shown like this on plans:

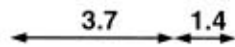

All measurements are given in metres.

NOTE: You don't have to worry about how thick the walls are or anything like that when you are doing your calculations. Just use the lengths as shown.

Now look at the plan below and try to answer the example questions on the page opposite.

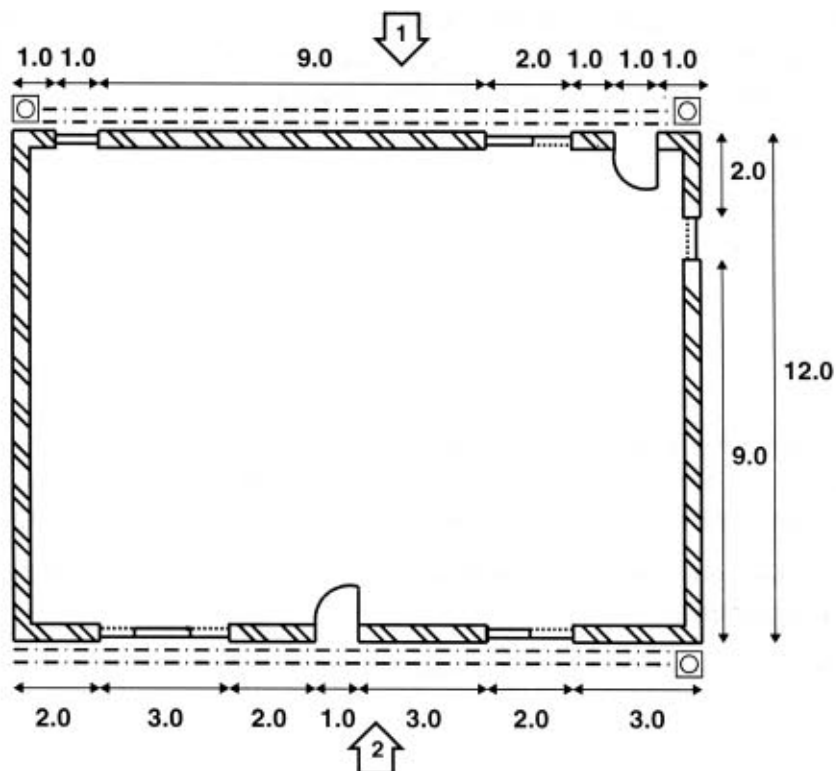

Example Questions

1. Look at the wall at which arrow 1 points. Which of the four pictures below is the most accurate view?

A

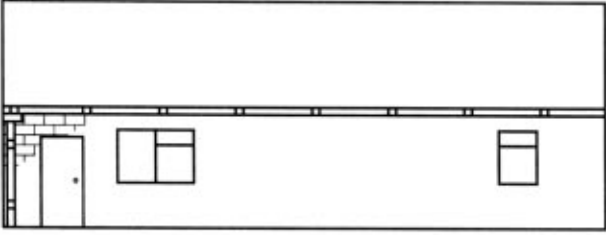

B

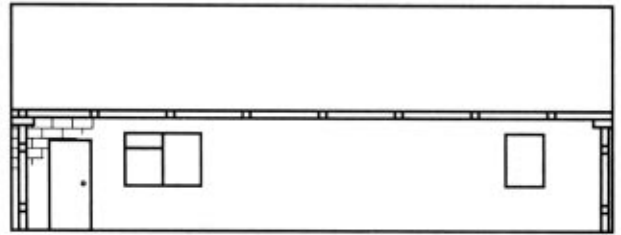

C

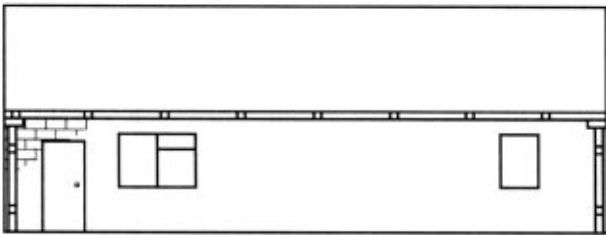

D

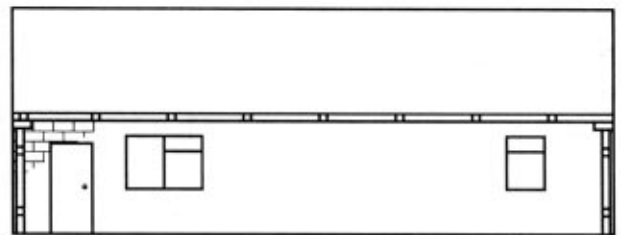

2. Look at the wall at which arrow 2 points. Which of the four pictures below is the most accurate view?

A

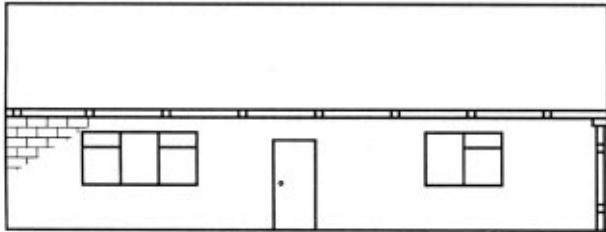

B

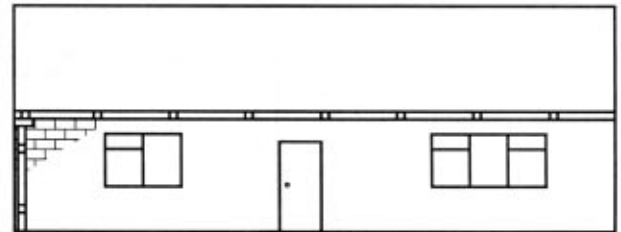

C

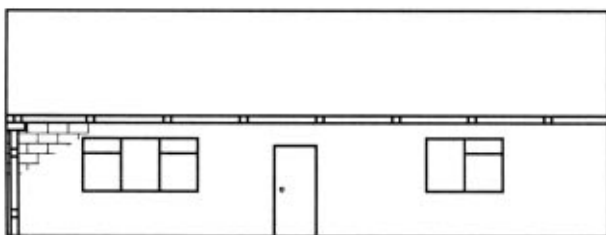

D

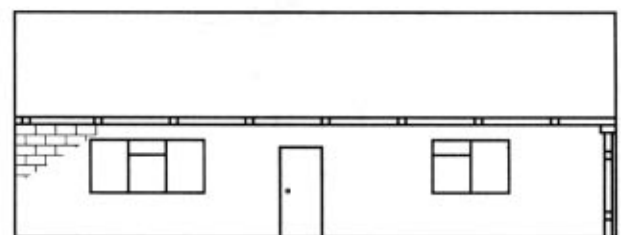

3. You are shown the width of the door and the windows in the wall indicated by arrow number 1 and the length of the wall on either side of these features. What is the total length of that side of the bungalow?

4. Look at the side wall which has a single window. You are shown the total length of the wall and the length of the walls on either side of the window. How wide is the window?

GO ON TO THE NEXT PAGE

Information Sheet 2

One of the ways in which houses differ is the type of door they have.

Doors with plate glass in them are shown like this on plans:

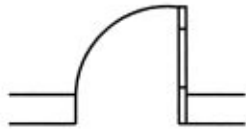

and like this in views:

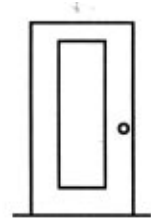

Doors with horizontal letter boxes are shown like this on plans:

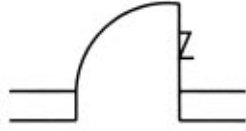

and like this in views:

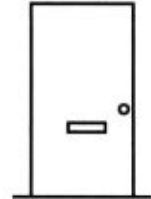

Doors with vertical letter boxes are shown like this on plans:

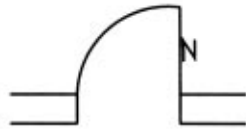

and like this in views:

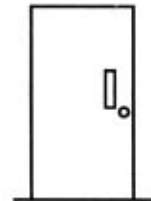

NOTE: Letterboxes can occur in walls as well as doors.

Look at the plan below and then answer the questions on the page opposite.

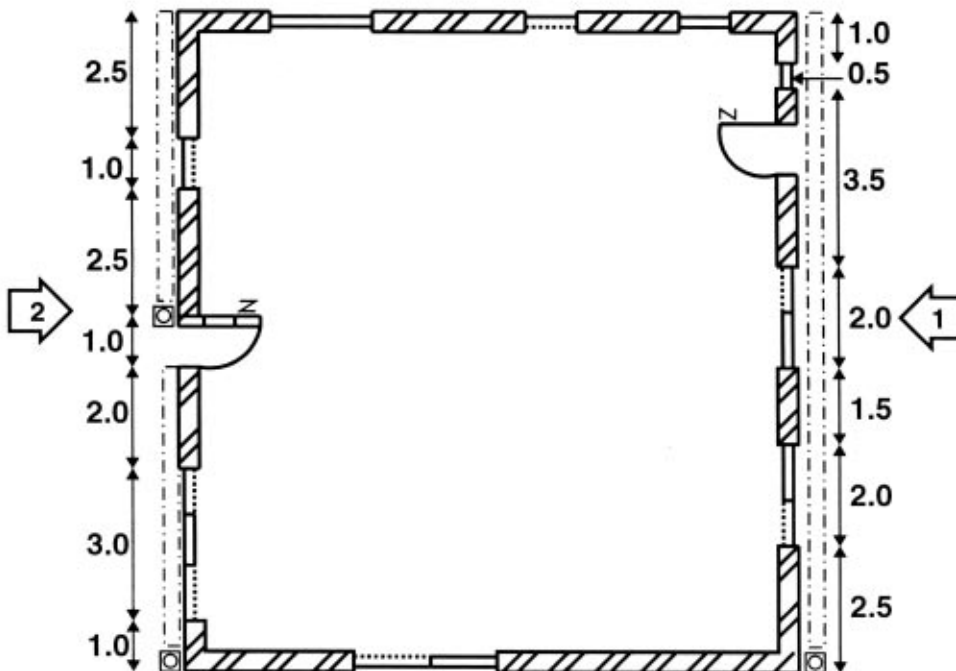

Example Questions

5. Look at the wall at which arrow 1 points. Which of the four pictures below is the most accurate view?

A

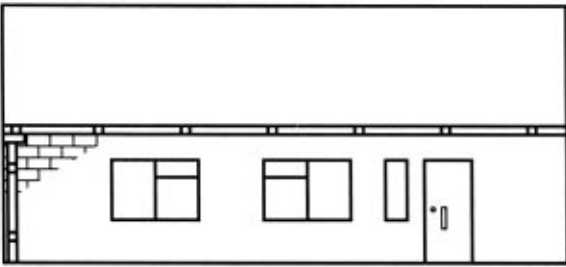

B

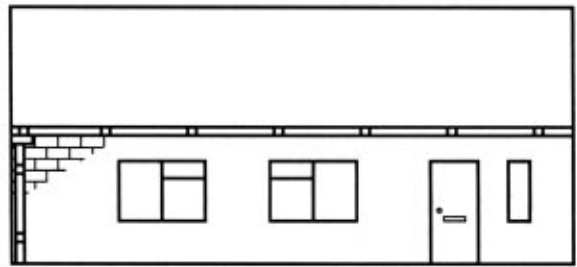

C

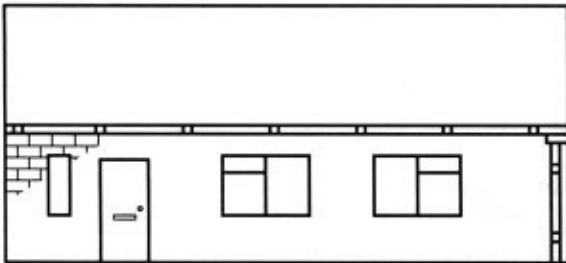

D

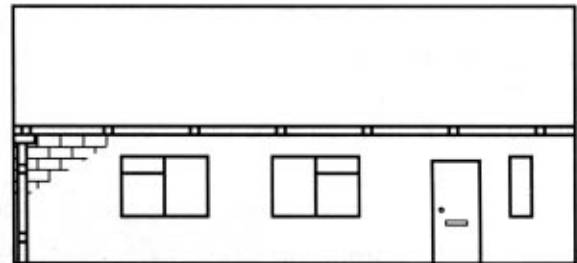

Most houses are built on a layer of concrete, the foundation, which is set into the ground. The type of concrete used depends on how acid the soil is. The bar chart below shows the reference numbers of seven types of concrete and the range of soil acid levels they can cope with.

Soil Acid Levels

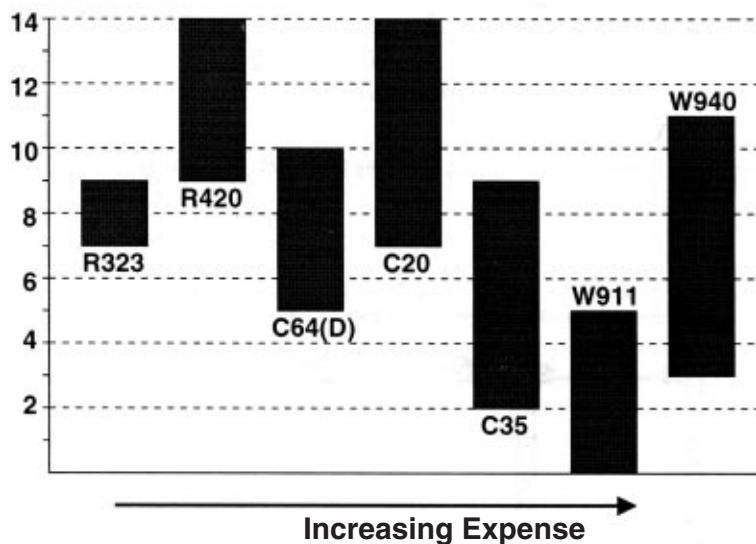

6. Look at the bar chart above. Which is the cheapest concrete you could use in soil with an acid level of 11?
7. Look at the bar chart above. Which is the cheapest concrete you could use in soil with an acid level of 3.5?
8. Look at the bar chart above. Which is the cheapest concrete you could use in soil which varies in acid level from 4 - 10?

Information Sheet 3

Garage doors are shown like this on plans:

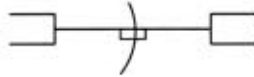

and like this in the views:

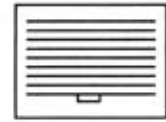

Walls built with breeze blocks are shown like this on plans:



and like this in the views:



Walls with stone cladding on the front of them are shown like this on plans:



and like this in the views:

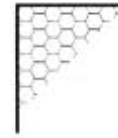

Porches are shown like this on plans:

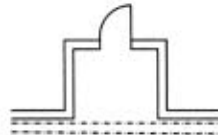

and like this in the views:

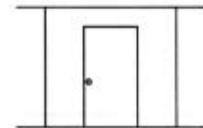

Paints, glues and other coatings are removed with chemical strippers, which vary in strength. The graph below shows how long different strippers should be left for them to work properly. If the stripper is left too long it may damage the underlying wood or metal.

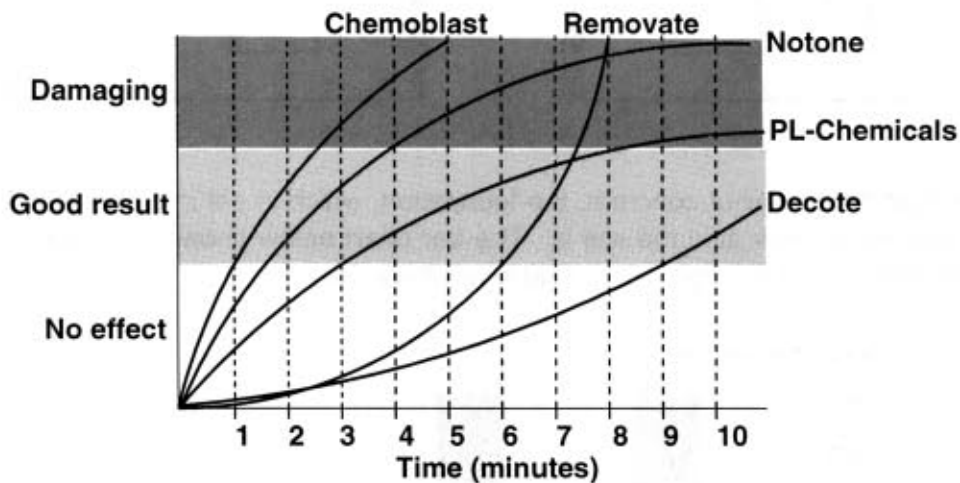

Now look at the plan below and then answer the questions on the page opposite.

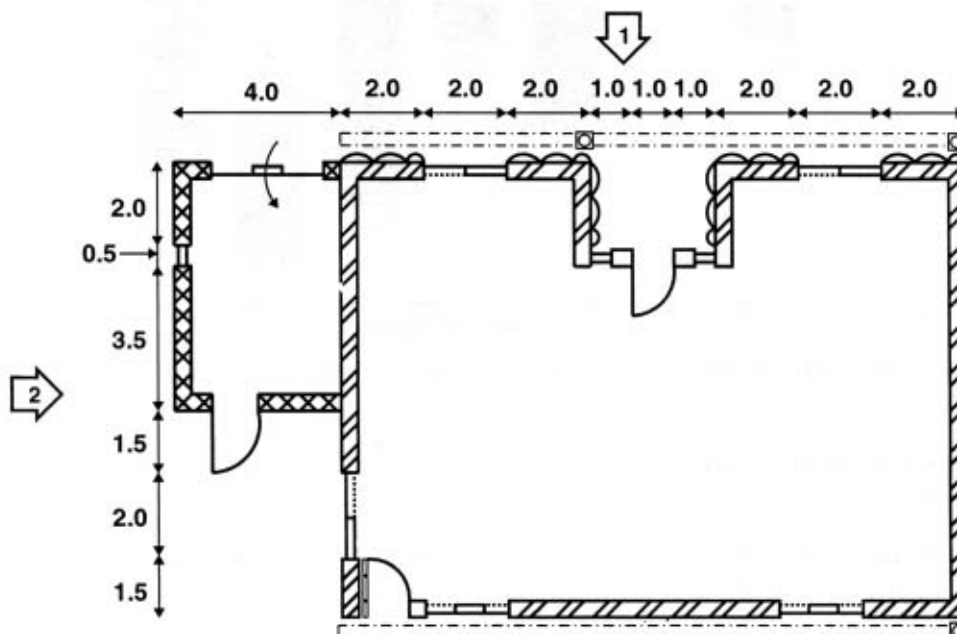

Example Questions

9. Look at the wall at which arrow 1 points. Which of the four pictures below is the most accurate view?

A

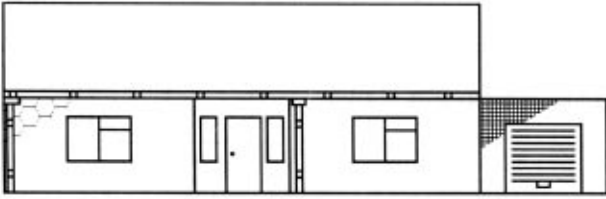

B

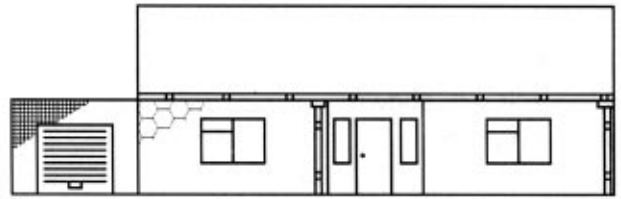

C



D

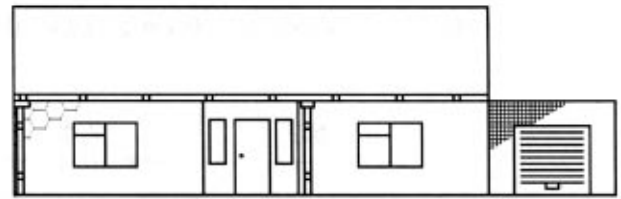

10. Look at the wall at which arrow 2 points. Which of the four pictures below is the most accurate view?

A



B



C

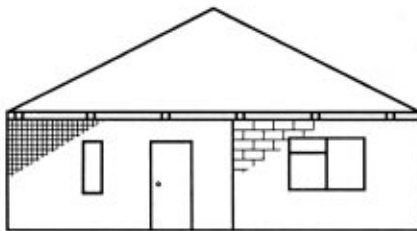

D

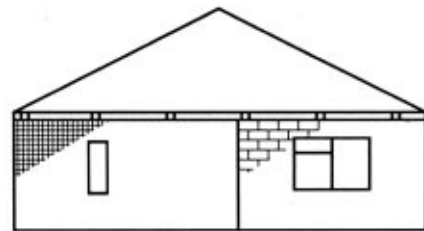

11. Look at the line graph opposite. What is the minimum length of time that PL-Chemicals needs to be left before you can expect a good result.
12. Look at the line graph opposite. How long can Notone Stripper be left before it starts causing damage?

GO ON TO THE NEXT PAGE

Information Sheet 4

Pebble dashed walls are shown like this on plans:

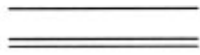

and like this in the views:

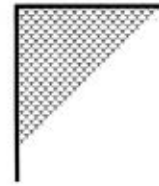

Windows which have window sills are shown like this on plans:



and like this in the views:



NOTE: Information which cannot be shown on a plan is sometimes given beside or below the plan in notes. Pay attention to these notes because the information can be important.

Now look at the plan below and then answer the questions on the page opposite.

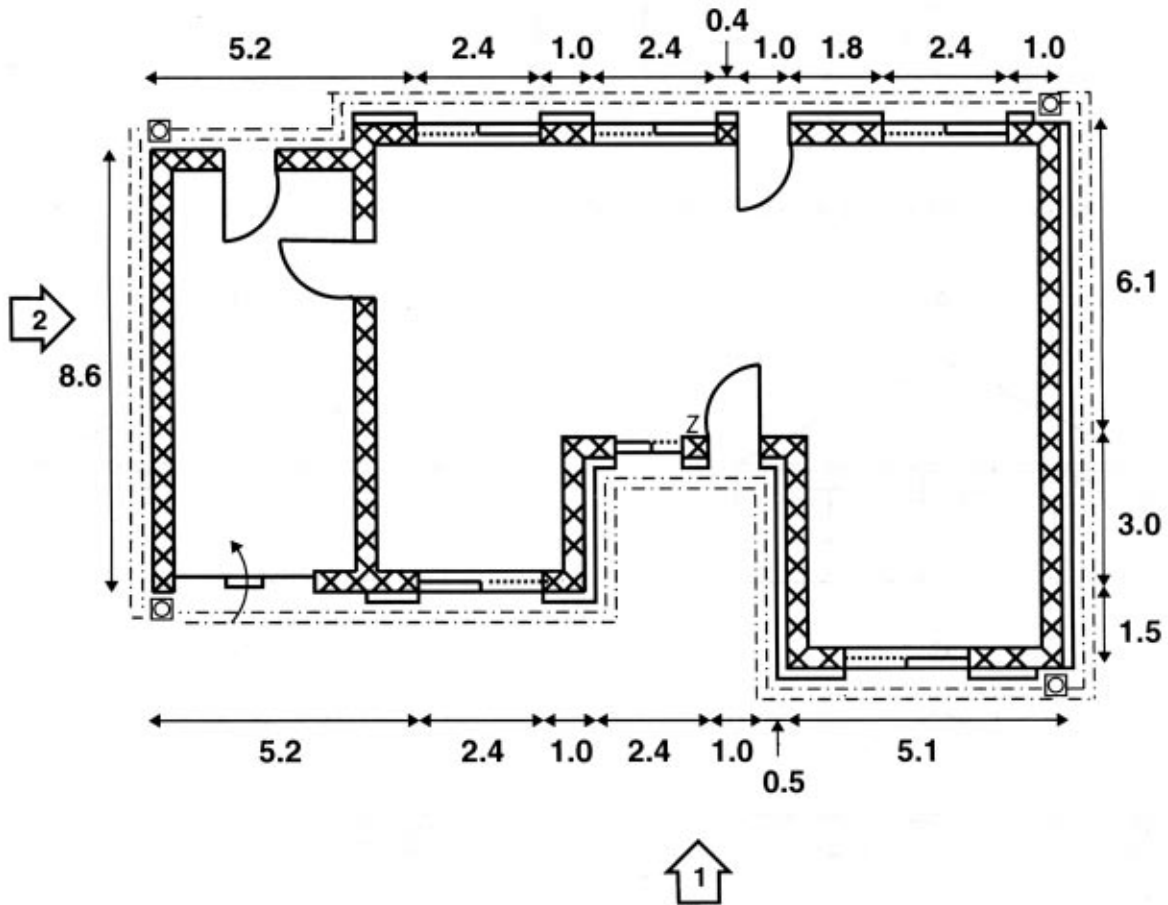

Notes

Height of top of windows:	2.5 metres
Height of top of doors:	2.2 metres
Height of top of walls:	3.5 metres
Height of top of letterbox:	1.4 metres

Example Questions

13. Look at the wall at which arrow 1 points. Which of the four pictures below is the most accurate view?

A



B



C



D

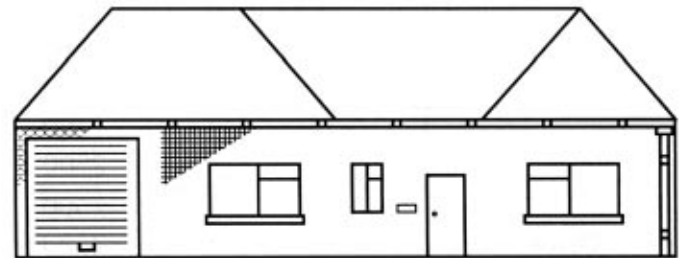

14. Some chemical stripper needs to be applied to the drainpipes. Which chemical stripper can be left the longest without causing damage?
15. Support brackets on guttering must never be more than 3 metres apart and there must be a support bracket on a corner. What is the least number of support brackets that would be needed on the garage side wall indicated by arrow 2?
16. Areas are worked out by multiplying the length of something by its height or width. Using the information provided, what is the area (in *metres*²) of the side of the garage indicated by arrow 2?

GO ON TO THE NEXT PAGE

Information Sheet 5

The type of concrete used for foundations depends on many factors apart from soil acid levels. The table below shows which concrete should be used given some of these factors.

Main Building Material	Number of storeys	Concrete density (psi)	Minimum depth of foundation (metres)	Concrete reference number
Wood	1	1500	3	LQ232
		1750	2.5	LQ245
		2500	2.5	ZJ114
	2	1500	3	LQ232
		2500	2.5	ZJ114
		3000	2	YD760
Brick	1	1750	3.5	LQ245
		2500	2.5	ZJ114
	2	2500	4	ZJ114
		3500	3	YD900
	3	2000	4	ZJ070
		3500	3.5	YD900
Stone	1	3500	4	YD900
		3500	4	YD900
		4000	3.5	WA440
	2	3500	4.5	YD900
		4000	4	WA440

Now look at the plan below and then answer the questions on the page opposite.

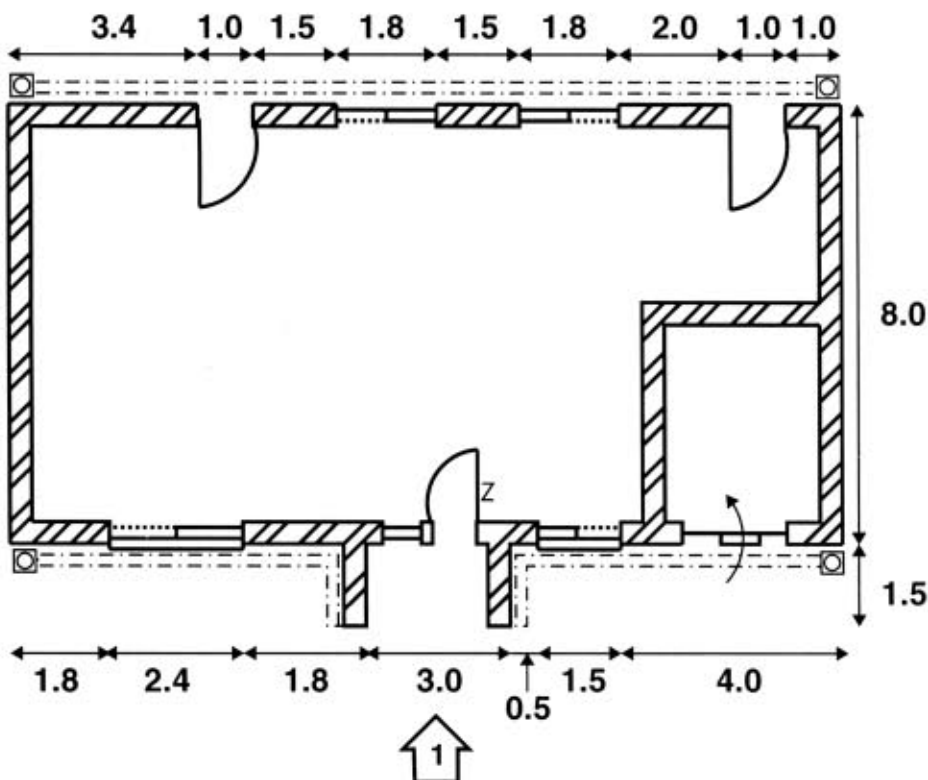

Notes

- Height of top of windows: 2.5 metres
- Height of top of doors: 2.2 metres
- 8.0 Height of top of walls: 3.0 metres
- Height of top of letterbox: 2.0 metres
- Height of top of roof (from the ground) 5.0 metres

Example Questions

17. Look at the wall at which arrow 1 points. Which of the four pictures below is the most accurate view?

A

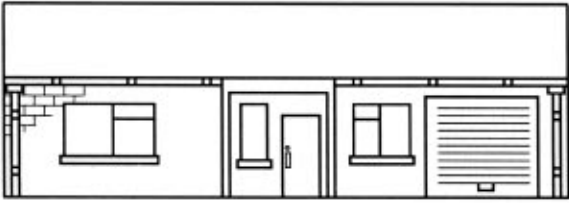

C

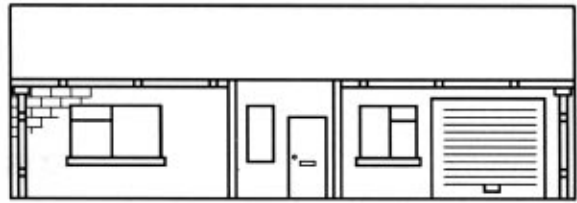

B

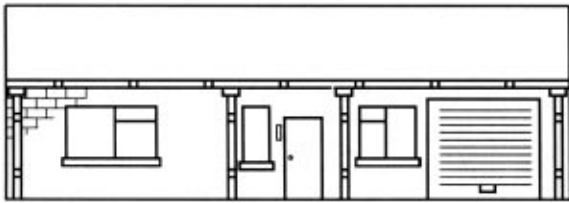

D

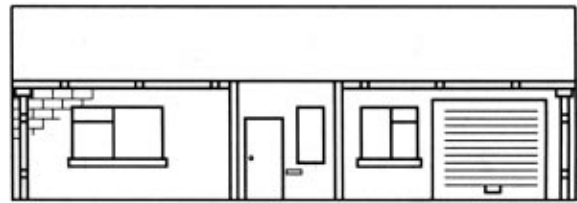

18. Look at the table opposite. A 3-storey brick house is going to be built. Rock has been found 3 metres below the surface and so the foundation can be no more than 3 metres deep. Which concrete should be used?
19. Look at the table opposite. A 3-storey house is going to be built. The house can be made of stone, wood or brick. Rock has been found 5 metres below the surface. Only concretes LQ245, ZJ114 and YD900 are available. What is the psi of the concrete which can be used?
20. Roofs are triangular in shape. To calculate the volume of a roof, multiply its length by its width and by its height and then divide the result by 2. What is the volume of the main roof space of the house above, not including the porch (in *metres*³)?

END OF PRACTICE EXERCISE

Answers

1	A <input type="checkbox"/>	B <input checked="" type="checkbox"/>	C <input type="checkbox"/>	D <input type="checkbox"/>	11	2 <input type="checkbox"/>	3 <input checked="" type="checkbox"/>	5 <input type="checkbox"/>	8 <input type="checkbox"/>
2	A <input checked="" type="checkbox"/>	B <input type="checkbox"/>	C <input type="checkbox"/>	D <input type="checkbox"/>	12	2 <input type="checkbox"/>	3 <input type="checkbox"/>	4 <input checked="" type="checkbox"/>	5 <input type="checkbox"/>
3	14 <input type="checkbox"/>	15 <input type="checkbox"/>	16 <input checked="" type="checkbox"/>	17 <input type="checkbox"/>	13	A <input type="checkbox"/>	B <input checked="" type="checkbox"/>	C <input type="checkbox"/>	D <input type="checkbox"/>
4	1 <input checked="" type="checkbox"/>	2 <input type="checkbox"/>	3 <input type="checkbox"/>	4 <input type="checkbox"/>	14	Chemoblast <input type="checkbox"/>	Removate <input type="checkbox"/>	PL-Chemicals <input type="checkbox"/>	Decote <input checked="" type="checkbox"/>
5	A <input type="checkbox"/>	B <input type="checkbox"/>	C <input type="checkbox"/>	D <input checked="" type="checkbox"/>	15	2 <input type="checkbox"/>	3 <input type="checkbox"/>	4 <input checked="" type="checkbox"/>	5 <input type="checkbox"/>
6	R323 <input type="checkbox"/>	C20 <input type="checkbox"/>	R420 <input checked="" type="checkbox"/>	W940 <input type="checkbox"/>	16	30.1 <input checked="" type="checkbox"/>	37.1 <input type="checkbox"/>	44.75 <input type="checkbox"/>	301 <input type="checkbox"/>
7	R323 <input type="checkbox"/>	C35 <input checked="" type="checkbox"/>	C64(D) <input type="checkbox"/>	W911 <input type="checkbox"/>	17	A <input type="checkbox"/>	B <input type="checkbox"/>	C <input checked="" type="checkbox"/>	D <input type="checkbox"/>
8	C64(D) <input type="checkbox"/>	C35 <input type="checkbox"/>	C20 <input type="checkbox"/>	W940 <input checked="" type="checkbox"/>	18	ZJ070 <input type="checkbox"/>	YD760 <input type="checkbox"/>	ZJ114 <input type="checkbox"/>	WA440 <input checked="" type="checkbox"/>
9	A <input checked="" type="checkbox"/>	B <input type="checkbox"/>	C <input type="checkbox"/>	D <input type="checkbox"/>	19	1500 <input type="checkbox"/>	2500 <input type="checkbox"/>	3000 <input type="checkbox"/>	3500 <input checked="" type="checkbox"/>
10	A <input type="checkbox"/>	B <input type="checkbox"/>	C <input type="checkbox"/>	D <input checked="" type="checkbox"/>	20	60 <input type="checkbox"/>	120 <input checked="" type="checkbox"/>	142.5 <input type="checkbox"/>	300 <input type="checkbox"/>

Published by the
ConstructionSkills
Bircham Newton, King's Lynn
Norfolk PE31 6RH

First published 1994

Revised edition first published 2000

Designed and developed by Psychometric Research & Development Ltd, St Albans, UK
© 2000 ConstructionSkills and Psychometric Research & Development Ltd

All rights reserved. No part of this publication may be reproduced, stored in a retrieval system or transmitted in any form or by any means, electronic, electrostatic, magnetic tape, mechanical, photocopying, recording or otherwise, without permission in writing from the ConstructionSkills and Psychometric Research & Development Ltd.

Printed in the UK

